

*Owners's
Manual*

COBRA

BEACH MAGNET



*High Performance
Under Water Metal Detector
with Ultra Deep 10" Search Coil*

*Super Advanced
System
High Powered,
More Depth!*

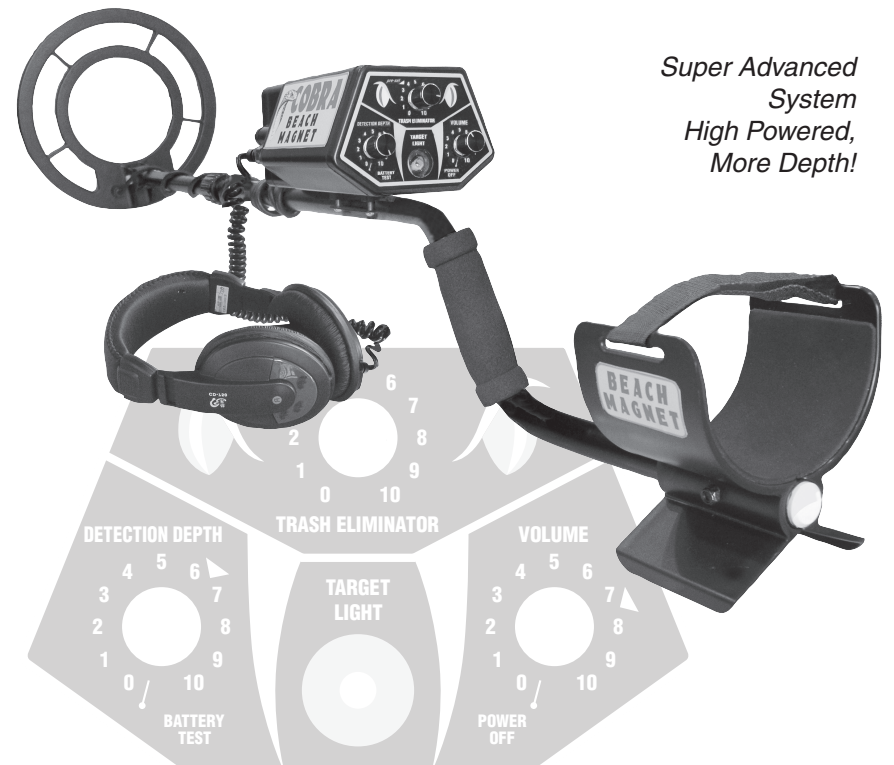

www.kellycodetectors.com



1085 Belle Avenue, Winter Springs, FL 32708
407-699-8700

The **COBRA Beach Magnet** is a high powered underwater metal detector that is easy to use. With a fully automatic circuitry that handles the ground balancing and tuning for you. The **COBRA Beach Magnet** is perfect for hunting on any wet beach or where high moisture becomes a problem.

Exclusive Features of the COBRA Beach Magnet:

- State-of-the-art high reliable circuitry.
- Full automatic tuning.
- Full automatic ground balancing.
- Full range VLF discrimination.
- Target response light.
- Volume control.
- Detection depth control.
- Audio battery test.
- The Detector is fully **water resistant to 132 feet.**



GLOSSARY OF TERMS

Air Test - A sensitivity test performed by outwardly moving various sized metal samples under the metal detector searchcoil to measure the distance limit of detection. This test is not always an accurate indicator of ground depth penetration capability. (See *Bench Test*)

Alkaline - A class of battery characterized by the ability to sustain longer periods of current drain and greater storage life when compared to the standard carbon-zinc type.

Bench Test - An air test to determine at what discriminate settings various metal samples are rejected or accepted. The test is conducted in a non-metallic area.

Cache - Any intentionally buried or secreted hoard of valuables.

Conductivity - The measure of a metal target's ability to allow eddy current generation on its surface.

Control Housing - A metal or plastic box which holds circuit boards, indicators, meter, controls and power supply.

Depth Penetration - The greatest measure of metal detector ability to transmit an electromagnetic field into the soil matrix and produce a target signal.

Discrimination - Adjustable circuitry which ignores or nulls audio responses from a specific conductivity range allowing positive responses to be heard from metals higher in conductivity above the discriminate control setting. Designed primarily to eliminate audio response from trash metals.

Double Blip - A signal characteristic common to elongated ferrous targets such as nails detected in the all-metal non-motion mode.

Faint Signal - A sound characteristic of targets that are sometimes deeply buried or very small in size.

False Signal - An erroneous signal created by automatic retuning overshoot, ground voids or highly mineralized hot rocks.

Ferrous - Descriptive of any iron or iron bearing material.

Metal - Metallic substances; iron, foil, nickel, aluminum, gold, brass, lead, copper, silver, etc.

Metal Detectorist - A person operating a metal detector in the field. This name is preferred by many over Treasure Hunter.

Mineralized Ground - any soil that contains conductive or non-conductive components.

Motion Discriminator - A detector type that requires searchcoil motion to activate its simultaneous ground balance and discriminate functions.

Non-Ferrous - Not of iron. Metals of the precious class (i.e. gold, silver, copper, etc.)

Pinpointing - Finding the exact target location with respect to a searchcoil's designated center. Accomplished by interpreting the centers of audio response width in perpendicular direction or scans.

Searchcoil - A circular (can be other shapes) plastic housing containing single or multiple transmit and receive windings in a specific orientation or configuration to emit and receive signals from ground and targets. (also called loop or coil).

Searchcoil Cable - An electrostatically shielded cable of conductors (wires) which convey signals to/from the searchcoil or control housing.

Sensitivity - The measure or capacity of a metal detector to perceive changes in conductivity within the detection pattern. Generally, the more sensitivity a detector can smoothly provide, the more depth it will achieve.

Signal - An audio response or visual indication alerting the operator that a target has been detected.

Slow Motion - A description of searchcoil speed required to operate the motion discriminate mode.

Sweep - the motion one employs in moving the coil.

MIND YOUR MANNERS

Filling holes and obeying **NO TRESPASSING** Signs are but 2 requirements of a dedicated metal detector hobbyist. A sincere request that KELLYCO makes to every user of a detector is that each place searched be left in a better condition that it was found. Thousands of individuals and organizations have adopted this formal.

Metal Detector Operators Code of Ethics:

- I will respect private and public property, all historical and archaeological sites and will do no metal detecting on these lands without proper permission.
- I will keep informed on and obey all laws, regulations and rules governing federal, state and local public lands.
- I will aid law enforcement officials whenever possible.
- I will cause no willful damage to property of any kind, including fences, signs and buildings and will always fill holes I dig.
- I will not destroy property, buildings or the remains of ghost towns or other deserted structures.
- I will not leave litter or uncovered items lying around. I will carry all trash and dug targets with me when I leave each search area.
- I will observe the golden rule, using good outdoor manners and conducting myself at all times in a manner which will add to the stature and public image of all people engages in the field of metal detection.

Warning!

Any metal detector may detect underground power lines, explosives or other items which when struck could cause personal injury. When searching for treasure with your detector, observe these precautions:

Do not hunt in an area where you believe there may be shallowly buried underground electric lines or pipes.

Do not hunt in a military zone where bombs or other explosives may be buried.

Avoid striking any line known to be or suspected to be carrying electrical power.

Do not disturb any pipeline, particularly if it could be carrying flammable gas or liquid.

Use reasonable caution in digging toward any target, particularly in areas where you are uncertain of underground conditions.

ASSEMBLY —

The detector is shipped fully assembled in one carton. Only two adjustments are necessary, and no tools are required.

1. Turn the search coil to the scanning position. It may be necessary to loosen the knobs securing the coil and then tighten them again. Make sure that the knobs are tightened (by hand) securely after the search coil is positioned.

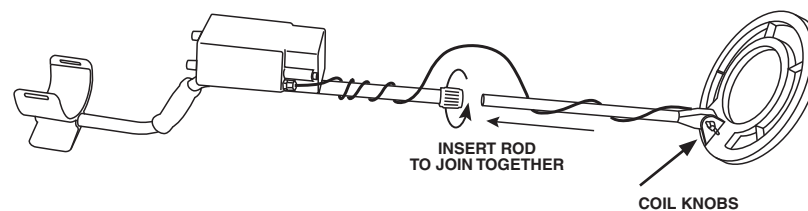

2. Install (6) "AA" batteries and then the detector will be ready for use.

CONTROL PANEL —

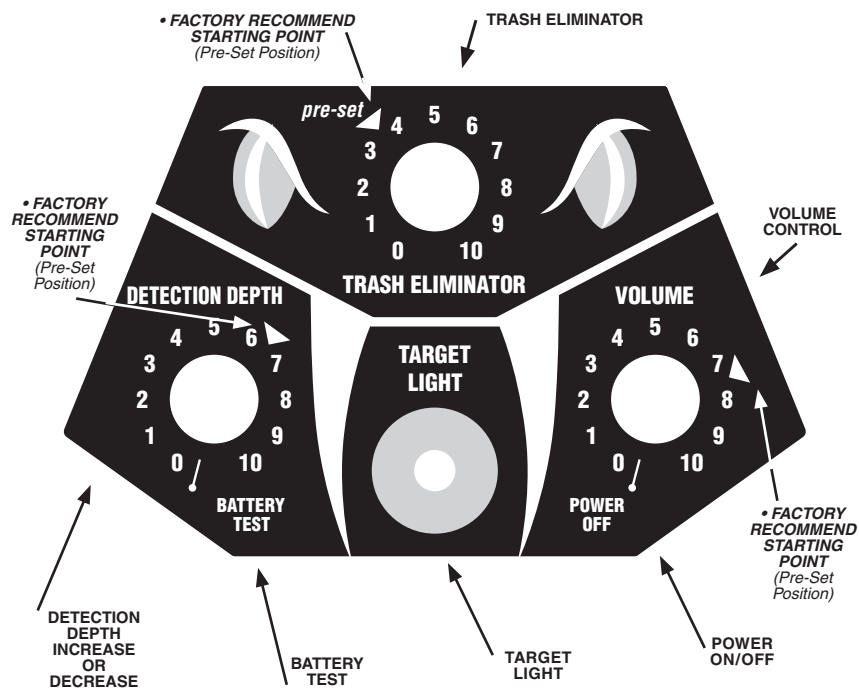

OPERATION OF THE BATTERY TEST CONTROL -

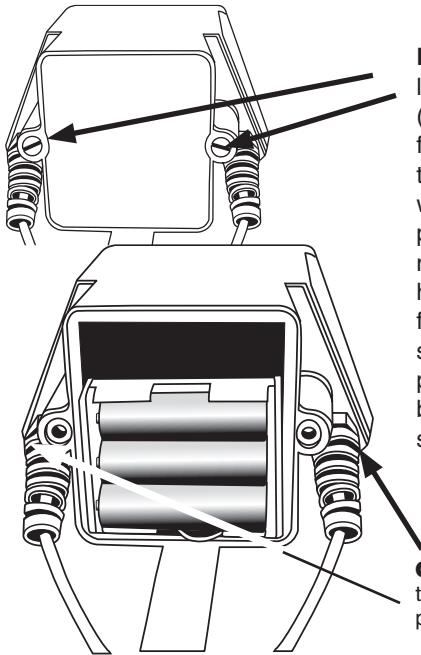

Installing the Batteries:

Locate the battery door cover and loosen both stainless steel screws (see inset) remove door and carefully remove (6) "AA" batteries from the installed battery holder. Replace with fresh "AA" batteries and please pay careful attention to the plus and minus direction of each battery. Place holder back in battery box. Pay careful attention to the rubber battery door seal that it is properly aligned and not pinched between door and battery box and tighten down both stainless steel battery door screws.

Note: DO NOT over tighten the screws!!

Caution: DO NOT Remove the two waterproof seal/strain relief's where the head-phone wire and search coil wires exit . . .

Testing the battery with the **Detection Depth Control** . . .

Before testing the batteries you must first make sure the **Volume Control** is set to its maximum position. Now you simply rotate the **Detection Depth Control** counterclockwise until it "clicks into the battery test mode", good batteries will give a loud audio and very bright target light. If the batteries are getting weak you will only get a faint audio volume and the target light will be dim. If you can't get any audio or target light when testing the batteries, it is time to replace them. Use only alkaline type batteries for the best performance and run time. You can also use good quality rechargeable batteries, but run time will be somewhat less.

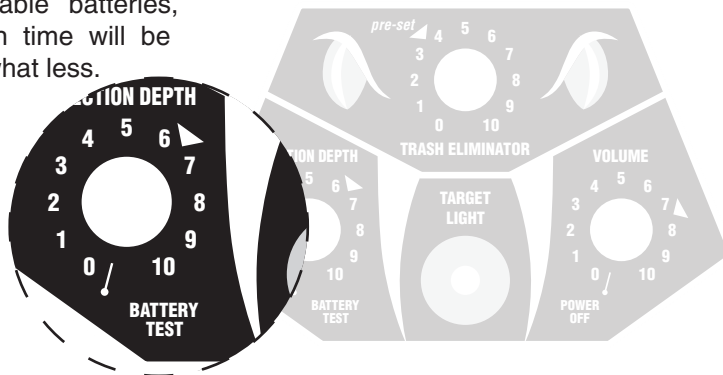

IN THE FIELD TIP FOR USING YOUR COBRA BEACH MAGNET

1. Always keep the bottom of the coil level with the ground. Try to maintain coil 1 inch off the ground at all times. You do not need to scrub the ground with the coil.

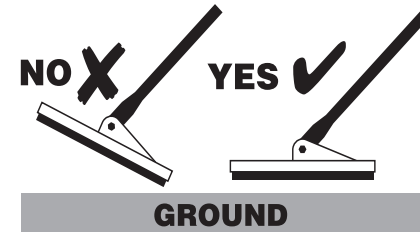

2. The Cobra Beach Magnet is an Ultra Slow Motion Metal Detector. When using this detector the coil must be in motion to detect any target. A sweep speed of about 2 feet per second is perfect. You can hunt as fast as you want or as your pace dictates.

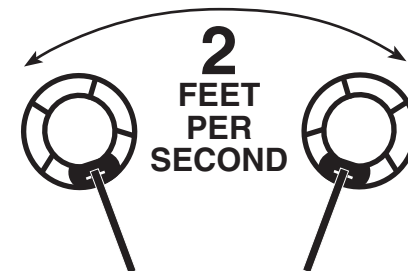

3. **Correct arm position.** Adjust the lower stem so that your arm is hanging in a comfortable position by your side with the coil about 1 inch off the ground.

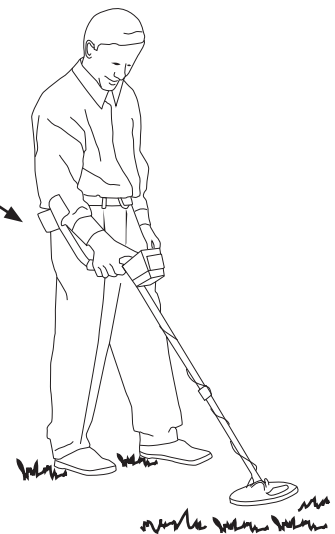

USING THE COBRA BEACH MAGNET UNDERWATER METAL DETECTOR —

The **Cobra Beach Magnet** is a slow motion type detector, in other words the coil must be in slow motion to respond to any target. By simply moving the coil back and forth over the ground this motion will activate the automatic ground balance and tuning circuits of your detector and keep it at its optimum tuning levels. When scanning the ground try to keep the search coil about 1 inch off the ground. **DO NOT** scrub the ground, you may get some "False Signals" by doing that. Please refer to the following drawings for the correct way to sweep and hold your metal detector.

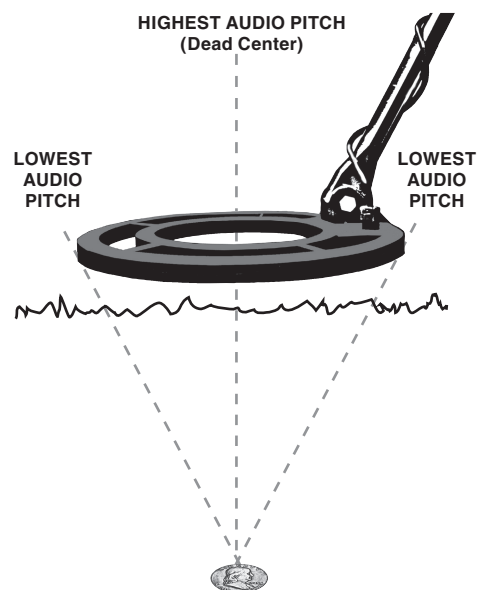
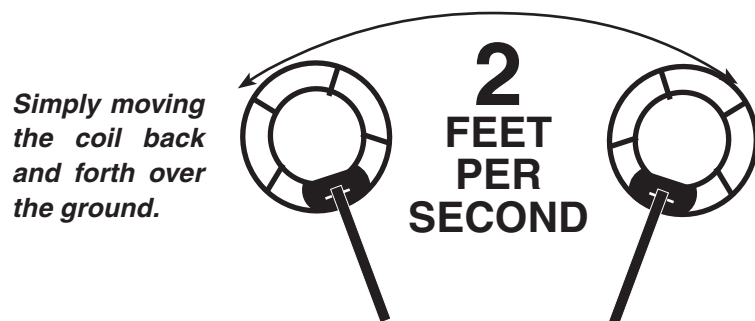

OPERATION OF CONTROLS —

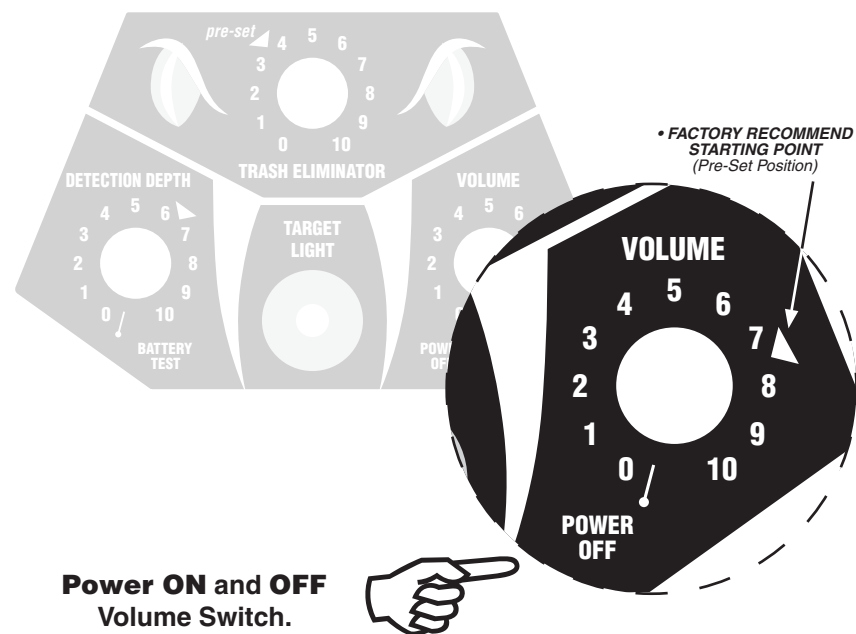

To operate and turn on the **Cobra Beach Magnet** simply turn the **Power/Volume Control** fully clockwise. Turning this same control counterclockwise will lower the headphone volume.

TIP: Adjust the headphone volume that is comfortable for your personal hearing.

After you have turned on the **Cobra Beach Magnet** you should now adjust the **Detection Depth Control** and the **Trash Eliminator Control** to their **Pre-set** positions. This is only a starting point and will help you get familiar with your new **Cobra Beach Magnet** underwater detector.

OPERATION OF THE DETECTION DEPTH -

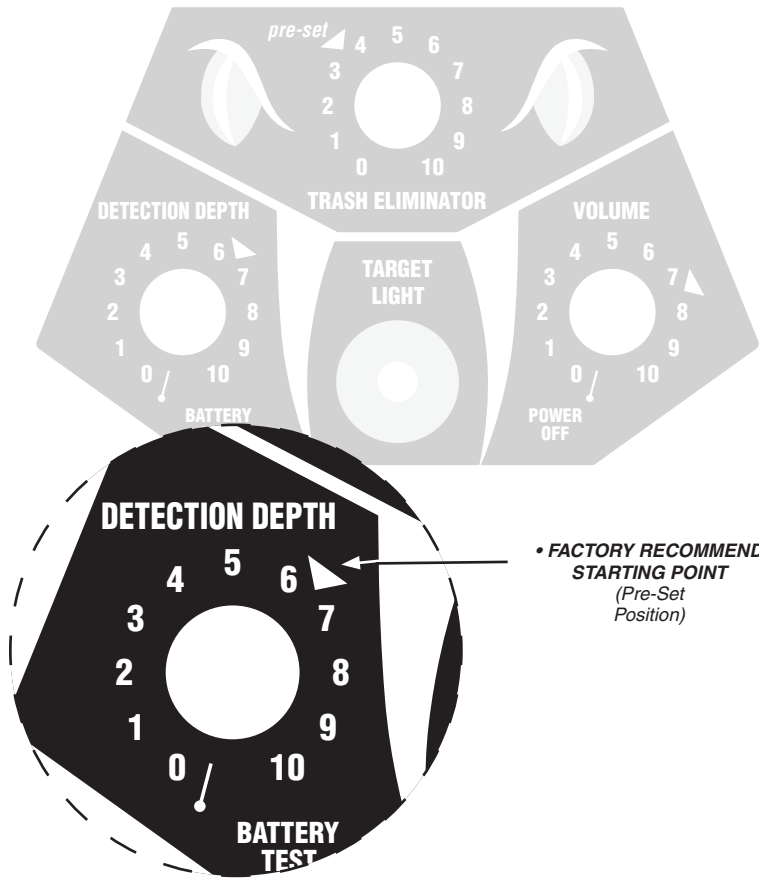

By starting out at the Pre-set point the **COBRA Beach Magnet** is set at the **normal detection depth range**. The normal range is good for most soil conditions, but by increasing this control clockwise to the maximum position you will get better depth on older coins. This control is extremely helpful in elimination false signals caused by high minerals. If you are experiencing false signals you should decrease this control until these signals are minimized.

TIP: Try running the **COBRA Beach Magnet** in the highest Detection Depth Range that you can (with minimal false signals) so the detector will give you maximum coin depth.

OPERATION OF THE TRASH ELIMINATOR CONTROL -

The **Trash Eliminator Control** is used to reject or discriminate unwanted trash targets. When the control is set to '0' your Cobra Beach Magnet will be in the All-Metal Mode and will respond to all targets. When you increase the control to a higher number the detector will begin to reject small iron targets first then most small foil pieces and then pull tabs. Study the below chart to get a better understanding of the different levels that trash target are eliminated.

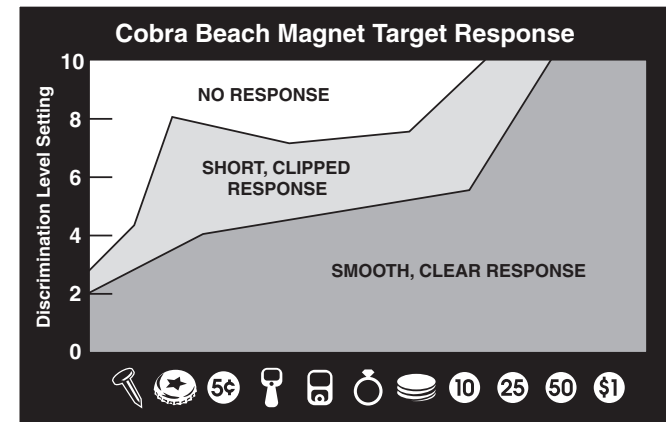
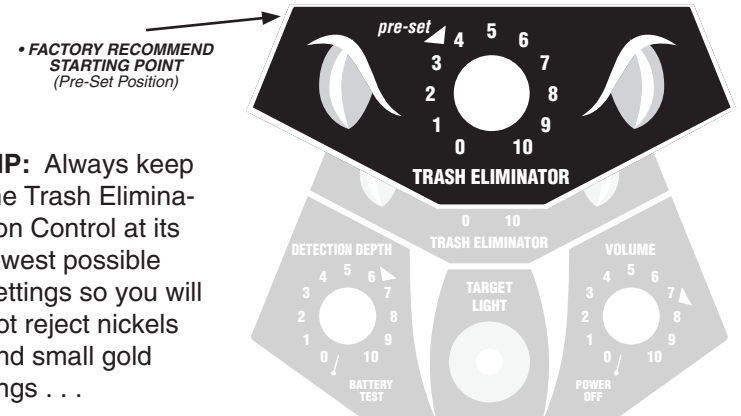

Note: Most **Eliminated Trash Targets** will give a broken or chattered sound when discriminated, this is normal and is a design feature of this underwater detector. It was designed this way so you can easily identify trash targets. Some trash targets will give No sounds at all. Practice using the **Elimination Control** by putting some different coins and trash items on the ground in a straight line about 10 inches apart. Pass each item once and then come back and increase the elimination control knob by one number and listen to the changes in the audio response on the trash targets as you keep increasing the control by one. Remember even good targets can be eliminated at the maximum discrimination settings.